

**UPGRADING AND REBUILDING OF A DEEP TOWED
VEHICLE SYSTEM FOR THE EU PROJECT “REDFISH”**

System evaluation and specification

John Dalen¹, Atle Totland¹, and Erik Stenersen²

¹ **Institute of Marine Research, Bergen**

² **Simrad AS, Horten**

LIST OF CONTENTS

1	INTRODUCTION	3
2	OBJECTIVES	3
3	MAIN ACTIVITIES	4
4	SYSTEM ANALYSIS AND SPECIFICATION	5
4.1	The vehicle mechanics	5
4.2	The acoustic units	7
4.2.1	Echo sounder	7
4.2.2	Acoustic data handling	8
4.3	Telemetry and environmental sensors	9
4.3.1	Depth sensor	9
4.3.2	Inclinometer	9
4.3.3	Temperature sensor	10
4.4	Signal transfer technology: Interfacing and connections	10
4.5	CONSYS: The control and monitoring system	12
4.5.1	Software for handling data from the ship and the towed vehicle	13
4.5.2	Software for displaying the ship echo sounder echogram	14
4.5.3	Remote control of the CONSYS PC	14
5	CONCLUSIONS	14
6	ACKNOWLEDGEMENT	15
7	REFERENCES	16
	APPENDIX I	17
A I.1	Details of the EK60-MK1 echo sounder	17
A I.2	Specifications and technical data of the PC for the control and monitoring system, CONSYS.	17

1 INTRODUCTION

From the EU project “Population structure, reproductive strategies and demography of redfish (*Genus Sebastes*) in the Irminger Sea and adjacent waters”, acronymed “REDFISH” it is particularly pronounced the need for collecting high quality data from fish distributions at great depths during most weather conditions having sufficient resolution in time and space, stability and confidence. Most of these requirements are met by applying a specially equipped deep towed vehicle.

The Institute of Marine Research (IMR), Bergen, is one out of few marine research institutes in Europe having an acoustically equipped operative (partly) deep towed vehicle system for fish and plankton mapping and at the same time possesses wide experience in towed vehicles for fishery biology applications. On the technology side the IMR and Simrad AS, Horten, have been cooperating within this field since the mid 70ies with special emphasis on deep towed vehicle technology during the 90ies (Dalen and Bodholt 1991, Dalen *et al.* 1995) as well as having followed relevant international projects of similar objectives (Kloser 1996, Kloser *et al.* 1996).

2 OBJECTIVES

Within subtask (sub-workpackage) 3.1 of the EU project “Abundance and demography; Survey evaluation by species, stock and size” we will further develop i.e. reengineer and rebuild an existing deep towed vehicle system. Such a system is obviously based on technology from several fields which is integrated. This comprises acoustic transmit and receiving units at two frequencies, telemetry sensors (i.e. depth, and tilt and roll angle sensors), signal interfaces and drivers for data transfer via the hybrid fibre optic and electrical cable, winch with a fibre optic rotary joint and electrical slip rings, and data handling units onboard the vessel.

The reengineering of the vehicle will include refitting with new echo sounder transceivers and transducers at minimum two frequencies, 38 and 120 kHz, new telemetry sensors with interfacing electronics, new technology for data transfer between the vehicle and vessel, as well as to design and produce a new and more proper control and monitoring system for optimal and safe operation. Sensors for temperature, salinity and light intensity may be included (options).

As the level of completion of the new Simrad echo sounder generation and that of the data link between the vehicle and the vessel by the end of 1999 and beginning of 2000 was lower

than expected by the time of writing the EU project plans, both IMR and Simrad have chosen a collaborative model in procuring the upgraded vehicle system more than the model where IMR directly purchased the different units from Simrad and other suppliers.

3 MAIN ACTIVITIES

To further develop the system we will put emphasis on applying techniques and methods of the latest technology. This is for new echo sounder technology, high-pressure tolerant split beam transducers, high capacity data transfer on fibre optic cable, and a powerful PC for control and monitoring purposes with sufficient hardware and software for signal handling and for graphic and numeric presentation of data and results. To a great extent we will apply on-the-shelf available technology meeting our requirements, but where needed to produce special required units.

The main activities of the development will include:

- evaluate and decide on the deep towed vehicle; payload volume and mechanical improvements,
- implement new echo sounder technology related to the vehicle and the surface vessel i.e. transceivers, interfaces and signal conditioning units for data transfer, and data handling and presentation on the vessel,
- implement new data communication technology i.e. high capacity Ethernet technology by fibre optic cable, and signal handling units in the vehicle and on the vessel,
- develop a control and monitoring system on the vessel for optimal and safe operation of the vehicle and vessel,
- adapt and implemented the recent developed modules of the echo integrating and target strength analysing system, the BEI system to quantitative deep water studies and mapping of fish, plankton and mikronekton,
- run two test surveys, one in October 2000, and the other one in May 2001, to test and evaluate the system functioning and performance. The last survey will also include particular quality assurance activities.

A general activity during January to August 2000 will be electronic acquisition via Internet of information for components and technology of the total system as well as direct meetings with actual suppliers.

4 SYSTEM EVALUATION AND SPECIFICATION

The total system is analysed and evaluated against defined requirements for mapping and quantitative estimation of biomass of deep water resident fish as well as for measuring and logging of environmental parameters. This includes technologies for all sensors, fibre optic and electric data transfer as well as for system control and monitoring. Special considerations have to be done to include the new echo sounder and signal handling technology. The main activities will be:

- acquire and process information about possibly modified vehicle,
- acquire and process information about the acoustic system and environmental sensors,
- evaluate the total amount of data and data transfer capacity on the fibre optic cable for the acoustic, environmental, and telemetry data respectively with regards to one or two fibre optic conductors, and for the signal conditioning and driver technology,
- specify and recommend on selected technology solutions for the total system,
- document the analysis and specification through a project report.

The basis for the requirement specifications and system solutions is formed on the know-how and competence at the Institute of Marine Research, Simrad AS, and that of relevant suppliers supplemented with otherwise acquired information on current technology. Financial reasons may put restrictions on our recommended solutions and selected electric devices.

Where specific choices of different devices have been made during the last phases of writing the report, the specifications of these devices are included.

4.1 The vehicle mechanics

The torpedo shaped vehicle has no depressor wings, and operates on the “dead weight” principle which means that only gravity is used to take the vehicle down to its operating depth. This is advantageous when it comes to controlling and maintaining its stable behaviour over the entire range of towing speed and in rough seas as the gravity always acts vertically downwards, independent of the vehicle’s tilt and roll angles. The vehicle may be operated in the depth interval 50-800 m within a speed range of 3-10 knots.

The body of the vehicle is comprised of three main sections; the front section or nose, the middle section, and the rear section which all are held together by a centre bolt continuing aft to the rudder. The outline dimensions and section composition are displayed in Figure 1.

Need: To improve the hydrodynamic stability of the vehicle by increasing its static margin¹ it would have been advantageous to increase the length of the vehicle i.e. the centre bolt.

Evaluation: There are absolute geometrical and mechanical restrictions from the width between the crane legs by the ship's rail where the vehicle has to be brought out and in. To overcome this when lengthening the vehicle we either have to produce a new A-frame like crane with greater width between its legs, or to rebuild the vehicle cradle by the ship's rail and change its way of operation.

Recommendation: None of the alternatives could be met by cost reasons.

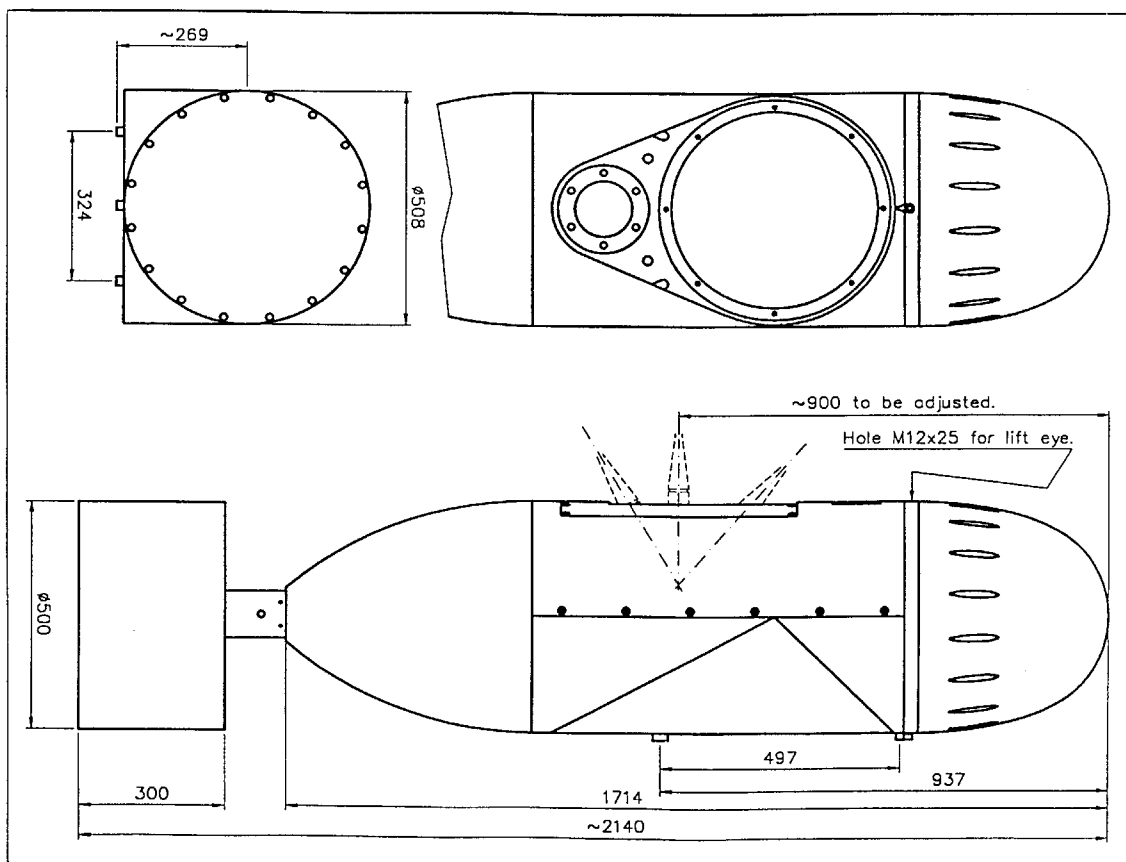

Figure 1. Outline dimensions and sections of the deep towed vehicle. Weight in air; approx 620 kg, weight in air, water filled; approx 800 kg, weight in water; approx 450 kg.

Need: The total amount of new electronics (acoustic transceivers, telemetry sensors, data converters, and interfaces) to be placed into the vehicle nose may require a larger volume than that of the original nose.

¹ Static margin: The ratio between “the distance from the hydrodynamic centre of the total vehicle to the tow point” and “the distance from the hydrodynamic centre of the main body to the tow point”.

Evaluation: The nose volume must be sufficient to include two acoustic transceivers, one multi-input RS232 to Ethernet converter, one multi-input HUB, one Ethernet switch and electrical to optical converter, one combined depth and temperature sensor with power supply, and one two-axial inclinometer. Additional power supplies for some of the electronic units may be necessary. For details see chapters 4.2 and 4.4.

Recommendation: The present volume meets the need of the electronics assembly and consequently we don't have to produce a new front section.

All electro-mechanical units holding all the electronic units within the front section must be mounted on frame like constructions which again has to be solidly mounted on the back plate.

4.2 The acoustic units

4.2.1 Echo sounder

The existing two-frequency echo sounder (38 and 120 kHz) of the vehicle system is a custom designed, modified version of the Simrad EK500. Although the quality of the acoustic data from this system has been excellent we have had some problems in maintaining stable functioning. The system had also some inherent shortcomings with regards to requested operational flexibility.

Need: To have an echo sounder which overcomes the mentioned problems and shortcomings as well as including all improvements of the latest echo sounder technology.

Evaluation: The newly developed EK60 Scientific Sounder is far better suited for this kind of application than the EK500, as an almost standard system can be directly applied. The major units of a one channel EK60 are one transceiver unit, the General Purpose Transceiver (GPT), one transducer, and a dedicated PC, where the PC is part of the echo sounder. The connection between the GPT and the PC is based on Ethernet technology. Four transceiver units may be connected to one PC. The major difference in our set-up compared to the standard system being data transfer over a long fibre optic cable having Ethernet switches and electric to optic and optic to electric converters at the downside and topside ends respectively. The receiving performance of the EK60 is rather similar to that of the EK500 with an instantaneous dynamic range of 160 dB.

The PC's Ethernet output communicating at 10/100 Mb/s may be connected to a work station for data storing and processing using for instance the BEI Post Processing Software (Foote *et al.* 1991) or the BI500 Post-processing system. During fall of 2000 the BI500 under Win2000 will be introduced to the market and will thus be available on the echo sounder PC itself (Anon 1999).

Recommendation: The EK60 Scientific Sounder (version MK1) will be purchased and installed partly in the vehicle and on the vessel. Strictly based on the fish measuring and estimation requirements from the EU project we will equip the echo sounder for just two frequencies, i.e. 38 and 120 kHz. Using more than one frequency, requires an Ethernet switch.

Two split beam transducers, the Simrad ES38DD and ES120-7DD respectively, will be installed in the middle section of the vehicle body. Both transducers are rated to 1000 m depth. The transducers will be connected via watertight connectors to their respective GPTs in the front section.

4.2.2 Acoustic data handling

The acoustic data acquisition from the EK60 and data handling and storing will be taken care of both by BEI traditionally installed on a work station, and by BI500 installed on the EK60-PC.

Need: To have available the most updated and powerful post processing system including the most recent developed and quality controlled data scrutinizing and interpretation modules for quantitative studies and mapping of deep water resident fish, plankton and mikronekton.

Evaluation: At present being BEI is advantageous to BI500 while it comprises some more general data handling modules, smarter storing modules, a noise quantification and removal module (Korneliussen 2000), and a module for performing specific frequency response analysis and presentations from two or more frequencies (Korneliussen and Ona 2000). The “noise quantification and removal module” is particularly useful when observing and scrutinizing data from deep water targets as will be the case during the redfish survey, while the “frequency response module” may be helpful when distinguishing between targets of different acoustic scattering properties during data interpretation.

Recommendation: Adapt and implemented on the ship-borne BEI system the recent developed modules for enhanced data scrutinizing and interpretation. Make available the BI500/Win2000 on the echo sounder PC.

4.3 Telemetry and environmental sensors

4.3.1 Depth sensor

Need: A depth sensor (pressure sensor) with a serial RS232 output (preferably) is required. It should have an accuracy of better than ± 1 m down to 1 000 m depth. The resolution should be better than 0.5 m, preferably 0.1 m. The supply voltage should preferably be 12 V DC.

Evaluation: The depth and temperature sensor electronics have to be housed in the front section while the sensors themselves are in contact with the seawater through a hole in the back plate of the front section. These characteristics put restrictions on the size and arrangement of the sensors. Approx. 15 companies delivering depth sensors have been contacted. Depth sensors with RS232 output is not commonly requested and were hard to find. For most suppliers the sensor we requested has to be a custom designed one. Out of the 15 suppliers four offers were roughly meeting our requirements. The prices which varied between 7 500 and 36 000 NOK (940 and 4500 Euro), did not necessarily reflect the performance of the sensor.

Recommendation: Nearly the cheapest sensor became our choice. It meets our technical requirements, but will result in more programming than originally anticipated. The depth sensor, DTS1000, from ScanSense AS has the following specifications:

- max depth: 1 200m,
- pressure accuracy: ± 0.1 % FS (full scale), i.e. ± 1 m at 1 000 m,
- resolution: 0.01 %, i.e. 0.1 m at 1 000m,
- sampling interval: 1 s,
- output signal format: RS232,
- supply voltage: 12 V DC.

4.3.2 Inclinometer

Need: A two-axial inclinometer sensing the tilt and roll angle of the vehicle with a serial RS232 output (preferably) is required. It should have an angle measuring range of $\pm 15^\circ$ ($\pm 30^\circ$ is acceptable) with a resolution of 0.1° or better. The supply voltage should preferably be 12 V DC.

Evaluation: The inclinometer is to be mounted in the front section in a very accurate manner to reflect the true tilt and roll angles of the free hanging vehicle.

Recommendation: The selected two-axial inclinometer, NS-45/P2, from HL-PLANAR has the following specifications:

- absolute accuracy better than 0.035 % of measured value.
- angle measuring range of $\pm 15^\circ$,

- resolution: 0.03°,
- sampling interval: Decided on request in its software.
- working temperature: -25 to 85° C,
- storage temperature: -40 to 85° C,
- output signal format: RS232,
- selectable supply voltage: 5-24V DC, 12 V applied.

4.3.3 Temperature sensor

Need: A temperature sensor will provide us with useful information of the temperature in relation to the fish distributions at the depths where the vehicle is towed although the sensor is not vital for the functioning of the vehicle. The supply voltage should preferably be 12 V DC.

Evaluation: The sensor is integrated with the depth sensor and is thus easy to implement requiring no extra converters. In our application there is no need for a It is sharing supply voltage with the depth sensor as well.

Recommendation: The temperature sensor, DTS1000, from ScanSense AS has the following specifications:

- absolute accuracy $\pm 0.2^\circ \text{C}$,
- resolution : 0.01°C ,
- calibrated temperature range: $0\text{-}25^\circ \text{C}$
- sampling interval: 1 s,
- output signal format: RS232,
- supply voltage: 12 V DC.

4.4 Signal transfer technology: Interfacing and connections

Interfacing and connections

Need: To convert the serial output signal format to Ethernet format from the telemetry sensors and the temperature sensor requires a multi-input RS232 to Ethernet converter. The supply voltage should preferably be 12 V DC.

To adapt the Ethernet electrical outputs from the two GPTs and from the RS232/ Ethernet converter to the fibre optic link in the vehicle, a Ethernet switch (Fast Ethernet Protocol) and electrical to optical converter is required. An equivalent, “inverted” version of this device is required at the top side end of the fibre optic cable in the Instrument Room linking the vehicle data to the ship’s Ethernet. The supply voltage should preferably be 12V DC.

A multi-input Ethernet HUB is required between the two GPT outputs, the output of the RS232 to Ethernet converter, and the Ethernet switch/converter input port.

Evaluation: The particular Ethernet switches and converters must be adapted to and serve the multimode fibre optic cable, and its optical wavelengths of 850 and 1300 nm as well as the communication rate of up to 100 Mb/s.

Recommendation: The present selected RS232 to Ethernet converter, the “Black Box Enhanced TCP/IP Terminal Server LEU9008”, has eight ports, one will be used for the combined depth and temperature sensors, one for the inclinometer, and the remaining ones are spare. The supply voltage is 24 V DC so we have to install the its own power supply in the vehicle.

Decide on an Ethernet to fibre optic switch and converter to fulfil the requirements.

Decide on a multi-input Ethernet HUB with at least three input ports.

Main connectors in the vehicle

All watertight connectors are located at the back plate of the front section. They are:

- two electrical connectors between the acoustic transducers and their respective GPTs,
- one hybrid electrical/optical connector between the tow cable and the Ethernet switch/converter.

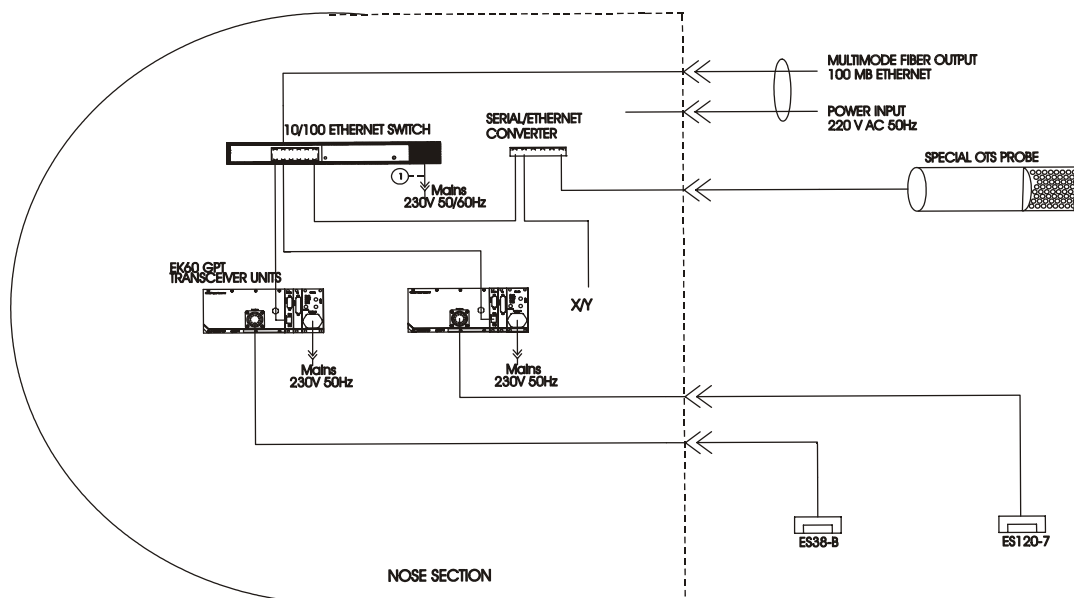

Figure 2. The front section with major units.

Figure 2 shows a sketch of the major units related to the front section. The HUB and the Ethernet switch/converter are displayed as one unit. The “special” OTS probe (oxygen, temperature, salinity) is omitted in the final recommended set-up.

Cable and connections

Due to long delivery time for the planned new cable (special production line set-up) in relations to when the outcome from the data transfer analysis was available and in relation to the rather short time to the start of the first test survey in October 2000, we have decided to use our existing cable for that survey. Applying just one fibre optic conductor is found sufficient for carrying the estimated amount of data at the chosen transfer protocol (Fast Ethernet) at 100 Mb/s. The new cable will be specified and ordered, and made available to the test survey in May 2001 and thereby to the main redfish survey during June-July 2001.

The existing double twisted, armoured tow cable is approx. 1200 m long, and has one multi-mode fibre optic conductor for data transfer communicating at 850 nm and 1300 nm, and two electrical conductors for the 220 V AC power supply. The topside end of the cable by the winch is connected via electrical slip rings to the 220V AC, and the fibre optic conductor via a fibre optic rotary joint to another fibre optic cable leading to the ship's Instrument Room. The output from this cable is connected to the ship's Ethernet and thereby the echo sounder PC and the control and monitoring PC via an Ethernet switch and converter. The downside end of the cable is connected to the electronics via a watertight connector at the front section back plate.

4.5 CONSYS: The control and monitoring system

Relevant experience and needs express that controlled and towed vehicles require a dedicated control and monitoring systems to make the towed systems more safe and user friendly during all operations. Additionally such systems raise the quality of the acquired data as well as the efficiency and quality of the data handling. Basic proposals for this towed system were already put forward during a previous project (Dalen 1988, 1989), but due to financial reasons just a limited part of the proposed concept was realized. Elements of that system will be put into the present developed one.

To supplementing the basic control and monitoring system it will be advantageous in optimised operation of the complete vessel and vehicle system during unexpected and hazardous situations to have a “towed vehicle system event simulator” for decision making and action taking.

Need: The control and monitoring system must meet requirements from the instrument operators, data collectors, vessel navigators, and the deck crew primarily for optimised operation of the towed vehicle system.

The operating needs of the vessel navigators would have been more fully met by additionally having available a “towed vehicle system event simulator”.

Evaluation: A dedicated, powerful PC onboard the ship will be used to monitor all relevant information from sensors in the vehicle and on the surface vessel. The PC will acquire and present data from the vehicle and vessel echo sounders, from the vehicle telemetry units and the winch, from the environmental sensors, from the ship’s GPS and optionally the ship’s log and gyro. The proper common time reference and all navigational data are provided to the ship’s Ethernet by the IMR Survey Logger System. From all this information control and decision making data will be generated to mainly operate the towed vehicle and partly the surface vessel, and to monitoring the data acquisition.

The basic models and the major part of the software for the “towed vehicle system event simulator” is available for the project (Støle-Hansen *et al.* 1989), but the software has to be ported from an older computer platform to present PC technology, as well as the software has to be converted into and supplemented as an online simulator. These software transformation and supplementing activities may be omitted due to cost reasons.

Recommendation: The selected PC will be purchased (actually delivered by the end of April).

It will hold the Win2000 operating system, large hard disc capacity, CPU clock frequency ≥ 450 MHz, Random Access Memory (RAM) ≥ 256 MB, a powerful graphical card, CD recorder, player and burner, sufficient number of input serial ports, Ethernet interface (10/100 Mb/s auto sense), a high resolution large screen (preferably a 21" screen with 1600 x 1200 pixels), a 3.5" floppy disk drive, mouse and keyboard. The detailed technical data and specification of the selected PC are found in Appendix 1.

4.5.1 Software for handling sensor data from the ship and the towed vehicle

The main program running on the control and monitoring PC, will be the present developed CONSYS software. The LabVIEW programming language is selected to develop CONSYS for two reasons:

- the power of LabVIEW is demonstrated as being among the most commonly used software languages world wide for this type of application (programming of virtual instruments),
- we have the required competence in LabVIEW at the IMR.

CONSYS will present numerous sensor data from the ship and the towed vehicle in graphical and numerical forms. Data is read from the Ethernet or the serial ports. System alarms will be given and all data are stored with the common time reference. The following sensor data is to be implemented in the program:

Ship:

Date, time, depth beneath ship, ship log, ship speed, ship heading, winch meter (length of cable in the sea), and ship position.

Towed vehicle:

Depth beneath vehicle, pitch and roll angles, and sea temperature.

4.5.2 Software for displaying the ship echo sounder echograms

On the CONSYS PC, the echograms from the ship echo sounder, the EK500, will be presented in real time as those from the vehicle echo sounder. Echograms from three EK500 frequencies are available on the PC. To be able to read the EK500 data from other clients than the BEI or BI500 systems a particular program, the EK Control (written in Visual C++ V 6.0), has been developed at IMR. Displaying the ship's echograms is not regarded as essential for the operation of the system though it will provide useful information together with the vehicle sounder echograms on the same spot.

4.5.3 Remote control of the CONSYS PC

This PC should be available for operation on certified access from any location onboard the ship. This is done using the remote control software PCAnywhere via the ship's Ethernet. From any PC connected to the Ethernet, the CONSYS can be operated on permission as if the user was sitting in front of the CONSYS PC. Several remote control software systems are available on the market. PCAnywhere was chosen for three reasons:

- IMR has performed a performance test of this software in 1998. PcAnywhere came out as one of the two best programs,
- we already have the necessary license and is satisfied with its performance,
- PCAnywhere is probably the most commonly used software of this type ensuring world wide support.

5. CONCLUSIONS

The deep towed vehicle system of the Institute of Marine Research has been analysed, evaluated and recommendations are presented to meet the needs from the EU project "REDFISH" in surveying and estimating the abundance of deep water resident redfish in The

Irminger Sea and adjacent waters. The IMR in collaboration with Simrad AS have broken the needs down to technical and operational requirements resulting in recommendations for solutions of different parts of the system. The main parts of the system reengineering and upgrading will be:

- provide and implement the new echo sounder, EK60 MK1, in the vehicle and on the surface vessel,
- provide and implement new data communication technology i.e. 100 Mb/s Fast Ethernet technology by fibre optic cable, signal conditioning units and interfaces for data transfer and signal handling units in the vehicle and on the vessel,
- develop and implement a control and monitoring system, CONSYS, on the vessel for optimal and safe operation of the vehicle and vessel,
- provide and implement new depth sensor, inclinometer, and a temperature sensor in the vehicle,
- adapt and implemented the recent developed modules of the acoustic data post processing system, the BEI system, as well as implementing the equivalent BI500/Win2000 in the EK60-PC.

The project manager and main author of this report is deeply sorry for delaying the analysing and evaluation report by several months due to cardiac sufferings when being obliged to be more or less “out of business” for more than two months. Actions were though spoken within the project not to let this event delay the procurement of the different hardware of any kind of the towed system.

6 ACKNOWLEDGEMENT

Besides the co-authors, Atle Totland and Erik Stenersen, the project team members, Hans Petter Knudsen, IMR, Geir Moen and Inge Skei, Simrad AS, have made valuable and important contributions to the system evaluation and specification.

Bergen 29 September 2000

John Dalen (s.)

project manager

7 REFERENCES

- Anon. 1999. Operator Manual. Simrad BI500 Post-processing system. Windows version. Simrad AS, Horten, Norway.
- Dalen, J. 1988. Acoustic abundance estimation of fish in deep waters. Pilot study report to the Norwegian Fisheries Research Council (in Norwegian). Institute of Marine Research report no FO 8802, June 1988, Bergen, Norway, 17 p.
- Dalen, J. 1989. Deep towed vehicle for assessing deep water fish stocks. Concept and operation simulations. Contr. to ICES FAST WG meeting 26-28 April 1989, Dublin, Ireland, 12 p.
- Dalen, J. and Bodholt, H. 1991. Deep-towed vehicle for fish abundance estimation, concept and testing. ICES CM 1991/B:53.
- Dalen, J., Bodholt, H., and Sogn, K.T. 1995. Deep-towed vehicle with optical fibre in tow-cable. ICES Int. Symp. Fish. and Plankt. Acoust., Aberdeen.
- Footte, K. G., Knudsen, H.P., Korneliussen, R.J., Nordbø, P.E., and Røang, K. 1991. Postprocessing system for echo sounder data. *J. Acoust. Soc. Am.* 90:37-47.
- Kloser, R.J. 1996. Deeply-towed transducer improves precision of acoustic surveys of benthopelagic fish. *ICES J. Mar. Sci.* 53, 405-413.
- Kloser, R.J., Koslow, J.A., and Williams, A. 1996. Acoustic Assessment of the Biomass of a Spawning Aggregation of Orange Roughy (*Hoplostethus atlanticus*, Collett) off South-eastern Australia, 1990-93. *Mar. Freshwater Res.* 1996, 47, 215-245.
- Korneliussen, R. 2000. Measurements and removal of echo integration noise. *ICES J. Mar. Sci.* 57: 1204-1217.
- Korneliussen, R. and Ona, E. 2000. An operational system for extraction of plankton and fish from mixed acoustic recordings. *ICES J. Mar. Sci.* (submitted).
- Støle-Hansen, K., Øgård, O. and Hallset, J.O. 1989. Analysis of a towed instrument fish (in Norwegian). SINTEF report STF48 F98008, Trondheim, Norway, 34 p.

APPENDIX I

A I.1 Details of the EK60-MK1 echo sounder

One EK60 channel consists of one transceiver unit, the General Purpose Transceiver (GPT), one transducer, and a dedicated PC being a part of the echo sounder. The maximum power output from the transmitter is 2 KW. The connection between the GPT and the PC is based on Ethernet technology running at 10 Mb/s. Up to four transceiver units may be connected to one PC. Each GPT consists of:

- four transceiver boards,
- one in/out (I/O) board,
- one digital signal processing board (DSP),
- a power supply unit. Supply voltage is 220V AC. The transceiver may supply 12V DC for other equipment.

The PC runs on the Windows 2000 operating system, and it meets specific operational and handling requirements. Its specifications are:

- *CPU main processor*: Intel Pentium III,
- *Clock frequency*: 733 MHz,
- *Random Access Memory (RAM)*: 128 MB,
- *Hard disk capacity*: 15 GB,
- *Auxiliaries*: CD ROM drive with CD burner and Ethernet interface and output for connection of two displays.

The PC and thus the echo sounder are operated from a mouse and a keyboard for annotation messages.

A I.2 Specifications and technical data of the PC for the control and monitoring system, CONSYS

- *Operating system*: Windows 2000. The EK60 echo sounder software may run on either WinNT or Win2000. In the future only Win2000 will support all the intended functionality of the EK60 software.
- *Hard disk*: 28.4 GB. The large hard disk is needed to store the huge amounts of detail data from coming versions of the EK60. A two-frequency configuration of the echo sounder will be installed in the towed vehicle.
- *CPU*: Intel Pentium III running at a clock frequency of 677 MHz. Faster processors are available, but are not recommended at the present time due to problems with system instability. The processor speed is not critical.

INSTITUTE OF MARINE RESEARCH, BERGEN

- *Random Access Memory (RAM):* 256 MB.
- *Graphical card:* ATI MAX 64 MB 2*CPU.
- *CD player.*
- *CD recorder/burner:* The collected data can be stored on CDs.
- *Serial ports :* 3 inputs RS232 ports. There will be one spare port for future system updates/alterations.
- *USB port:* The serial port of the future. Not presently used.
- *Ethernet card:* Net Nic 3Com 3C905BTX-NM PCI 1: 10/100 Mb/s auto sense card with twisted pair port. Will be connected to the ship's Ethernet.
- *Screen:* EIZO F980 21" Trinitron with high resolution, i.e. 1600 x 1200 pixel. The large screen with this resolution is needed to display the four intended programs simultaneously in a proper manner.
- *Floppy disk drive:* 3.5".
- *Mouse.*
- *Keyboard.*